



BBT ANTENNAS INC

Model NO: BBT-1718PW20V08

Type :Grid Antenna

Application:

- ★1710-1880MHz wireless access system
- ★Digital trunking wireless communication system.
- ★Base station/repeater communication system
- ★long distance transmission coverage

Features:

- ★High gain、 long transmission distance,good performance.
- ★Grid reflection design, strong wind resistance.



Specifications:

Electrical	
Model Number	BBT-1718PW20V08
Frequency Range	1710-1880MHz
Polarization Type	Vertical
Gain	20dBi
3dB Beam-Width. H-Plan	13°
3dB Beam-Width. E-Plan	12°
VSWR	≤1.5
Front to Back Ratio(dB)	≥20dB
Input Impedance	50Ω
Max Input Power.	100W
Lightning Protection	DC Grounded
Mechanical	
Connector Type	N-Type Female
Dimensions H*W*D (mm)	Φ800 (mm)
Radome Material	Aluminium
Radome color	white
Operating Temperature Rang	-40°C/+60°C
Support Pole Diameter	φ30-φ60(mm)
Rated Wind Velocity	60m/s

VSWR:

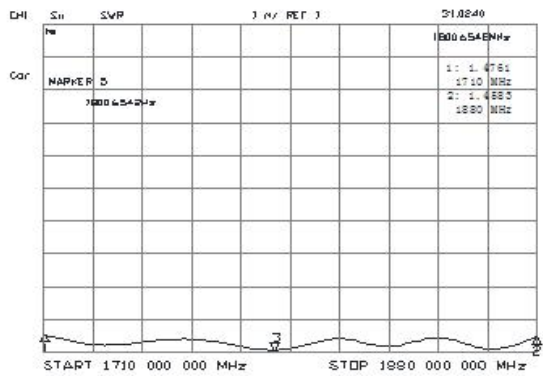

Radiation Pattern:

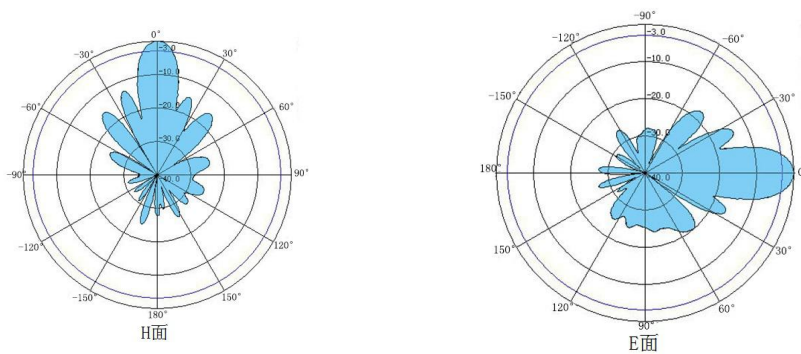

BBT ANTENNAS INC

Tel:(8620)38867118 Fax:(8620)38860481 <http://www.bbtantennas.com>